

LASER MARKING SYSTEMS

WORKSTATIONS



LASER



Laser RANGE

L-Box
XL-Box





LASER TECHNOLOGY: FAST AND HIGH QUALITY MARKING ON ALMOST ALL MATERIALS !

Part traceability is essential for compliance with quality standards. Laser marking allows manufacturers to automate marking operations and ensure a high level of control.

The laser technique consists in generating a beam from a laser source, amplifying it and directing it to the part via mirrors. The energy delivered by the laser changes the surface of the material under the focal point. It may heat up the surface and subsequently vaporize the material. This is how material is removed from the surface to create a marking or an engraving.

The fiber laser technology -Ytterbium pulsed-is a cutting edge solution for marking : high performance, robust, easy to set up, without maintenance cost. This technology is used for Direct Part Marking (DPM) or label marking on almost all materials regardless of hardness or surface textures. Laser is recommended for high-volume production, where speed and accuracy are essential.



LASER WORKSTATIONS

SIC Marking lasers are the core of our marking workstations. They could be integrated in a production line if required, but they can be used as autonomous and versatile workstations. These systems can fit with low rate production, and even high rate production with additional tooling and customization. Change size of the body, manufacture dedicated tooling system, add new axis movements can be provided per request.

HIGHLIGHTS

■ Robustness and reliability

- Extended component life expectancy $\geq 100\,000$ h
- Maintenance free
- Warranty up to 5 years

■ Performances

- Marking on all type of material
- Surface or hollow marking
- Standard 1D (bar codes) and 2D (DataMatrix) code capability
- Marking high definition logos and images
- High quality marking
- Deep marking

■ Security

- Class 1 security laser (EN 60825-1 standard)

■ User-friendly

- Ergonomic door : soft opening
- Access the marking zone from 3 sides with height of 200mm / 7.9 inches
- Large viewing window
- Reduced width

■ Fiber laser

- Doped Ytterbium fiber laser source, diode pumped
- Fast and high quality marking

L-Box

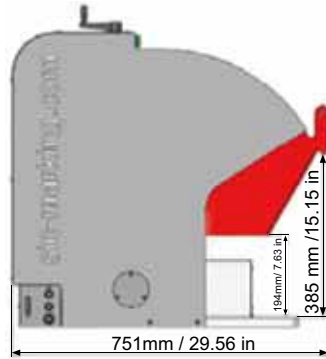
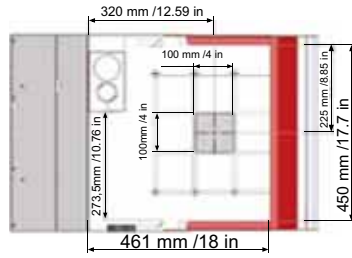

■ ADVANTAGES OF L-Box

- **USER- FRIENDLY**
- Ergonomy
- Opening on 3 sides
- LED lighting
- Working area 370 x 450 mm / 14.5 x 17.7 in



XL-Box

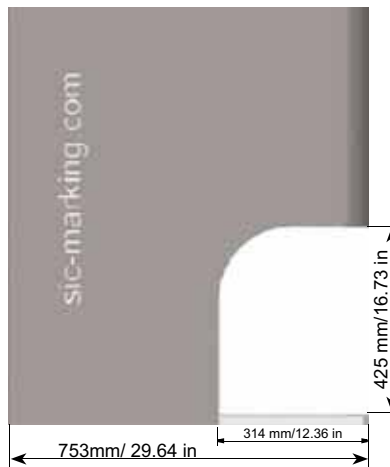
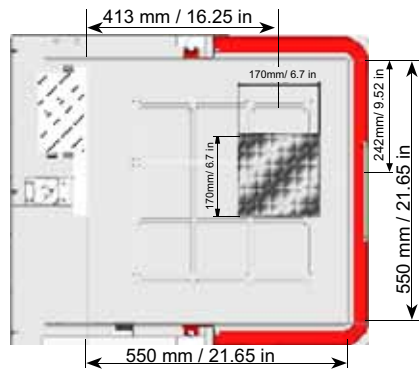

■ ADVANTAGES OF XL-Box

- **HIGH VOLUME, HIGH EFFICIENCY**
- Automatic door and motorized Z column
- Wide opening on 3 sides
- LED lighting
- Working area 550 x 560 mm / 21.6 x 22 in



TECHNICAL FEATURES

L-BOX

XL-BOX

Marking window	100 x 100 mm (optional 170 x 170 mm) 3.9 x 3.9 inches (optional 6.2 x 6.2 inches)	170 x 170 mm (optional 210 x 210 mm) 6.2 x 6.2 inches (optional 8.3 x 8.3 inches)
External dimensions	503 x 781 x 700 mm (19.8 x 30.7 x 27.6 inches)	653 x 753 x 887 mm (25.7 x 29.6 x 34.9 inches)
Dimensions of parts to mark	Maximum height : 235 mm (9.3 inches) Maximum length : 450 mm (17.7 inches)	Maximum height : 263 mm (10.4 inches) Maximum length : 560 mm (22 inches)
Focal distance settings	Manual column with counter (motorized in option) and built-in laser focus	Motorized column (optional software direct setting) and built-in laser focus

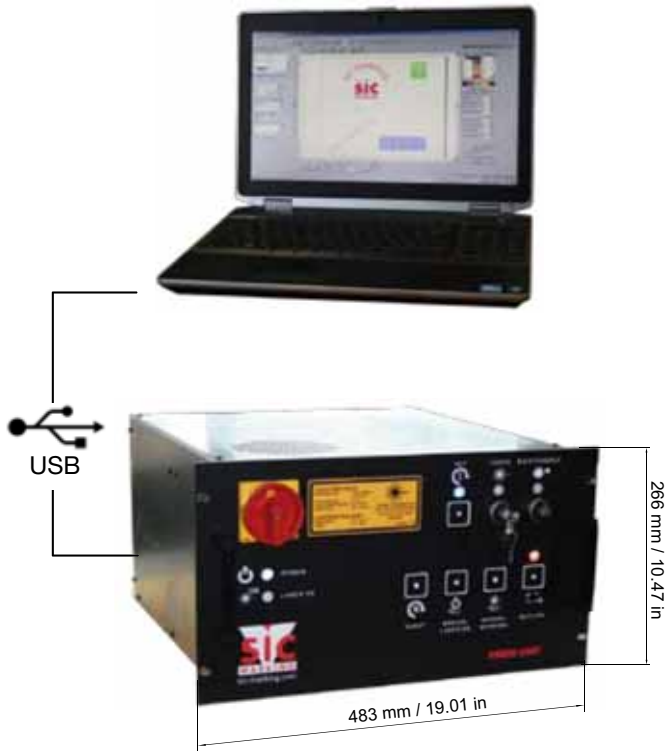

ADVANTAGES OF FIBER UNIT

Reliability and performances

- Doped Ytterbium fiber laser source, diode pumped
- 3 axis control (4 axis in option)

Security

- Integrated safety loop (class 1)

Control

- Controlled with « SIC LASER PC SOFT »
- USB Interface, Windows environment

CHARACTERISTICS

- Operation mode: Pulsed (20 to 500 KHz)
- Wavelength: 1 064 nm
- Average power: 10 W, 20W or 50 W
- Peak power: 10 kW
- Laser tuning: Edge viewing of marking
- Cooling: by air only
- Warranty: 24 months (except for optics)
Warranty extension up to 5 years in option

SOFT TECHNICAL FEATURES

CONTROL WITH SIC LASER PC SOFTWARE

Functions	Creation and editing of marking files (drawing, text, bar code, Datamatrix, ...)
Laser tuning	Several pen settings (speed, power, frequency, ...)
Fonts	TrueType, 1D bar code and 2D code (Datamatrix)
Import function	Pictures (.bmp, .jpg), and vectorial files (.plt, .dxf, .ai)
Data base	Link with external files (.txt, .xls)
Cylindrical parts	Rotary axis (optional)
Input/Output	Integrated

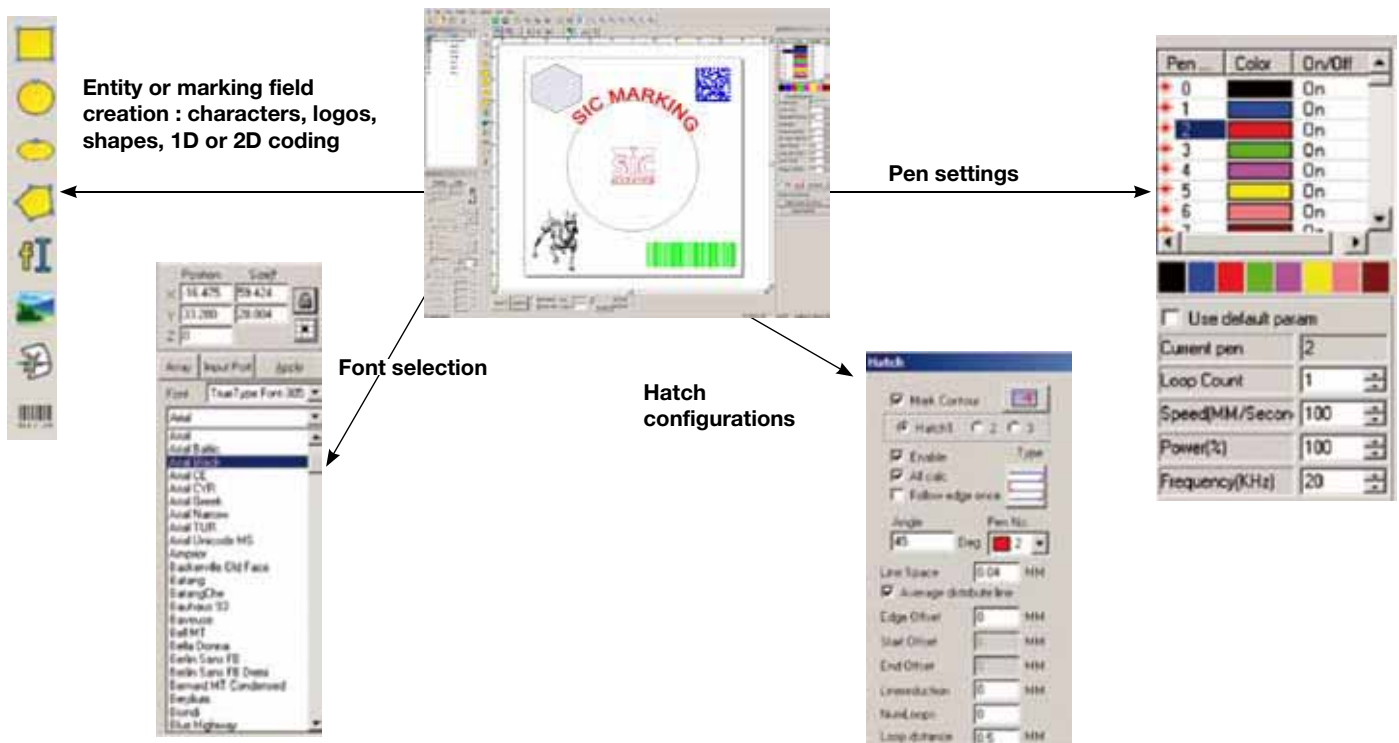

Options, applications and marking

OPTIONS



Chassis dedicated to L-Box laser

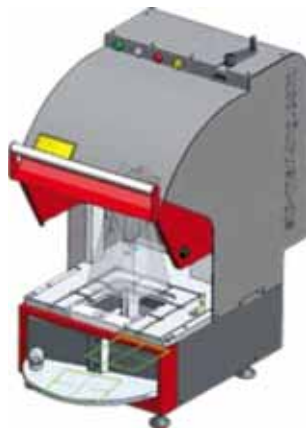

Swing plate



Parts loading drawer

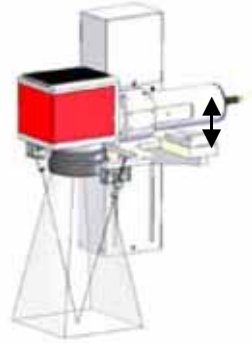

Motorized Z-Axis



Rotary axis (D)



Barcode and Datamatrix reader



Fume extraction system



Laser safety glass

APPLICATIONS



4 axis laser station



Fully automated laser workstation



Tag-feeder laser station

MARKING

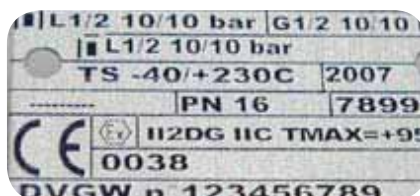

Mark today
Identify tomorrow



SIC MARKING, THE MARKING SOLUTIONS LEADER

SIC Marking is an international company dedicated to the development of permanent marking solutions & automated identification for complete traceability of industrial components.

SIC Marking has developed a full range of exclusive marking machines - dot-peen, scribing & laser technologies - and services.

SIC MARKING, A WORLDWIDE NETWORK 40 DISTRIBUTORS AND 5 SUBSIDIARIES

SIC Marking
13, route de Limonest
ZAC de la Braille
69380 LISSIEU - FRANCE
Tel : +33 (0) 4 72 54 80 00
Fax : +33 (0) 4 78 47 39 40
info@sic-marking.com
www.sic-marking.com

SIC Marking® ACTIVITIES

PERMANENT
MARKING



CONVENTIONAL
MARKING



DOT PEEN



SCRIBING

INDUSTRIAL
VISION



INDUSTRIAL VISION

TURNKEY
SOLUTIONS



TURNKEY
SOLUTIONS

(2013/07) SIC Marking® reserves the right to modify equipment specifications at any time - This document is not contractual.



www.sic-marking.com

